



Ceramic Infrared Long Panel Radiators FSL



Figure 1: Elstein FSL series

Elstein FSL long panel radiators are ceramic infrared radiators with a low overall height, designed for operating temperatures up to 550 °C and surface ratings up to 45 kW/m².

They have two sockets with integrated litz fixing wires, which are put through corresponding holes in the mounting sheet and twisted behind it. In this way FSL radiators are easy to install and are space-saving. No special pre-punched holders or reflector plates are required for the assembly.

FSL series radiators are particularly suitable for lamellar heating tasks due to their long narrow design.

An example for lamellar heating tasks can be found in the lamp industry where FSL radiators are used for curing the coating of fluorescent tubes.

Elstein FSL long panel radiators are available in two designs with 300 W and 600 W.

FSL

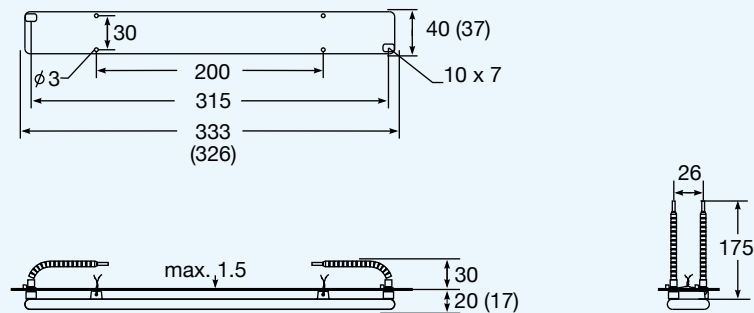

FSL/2

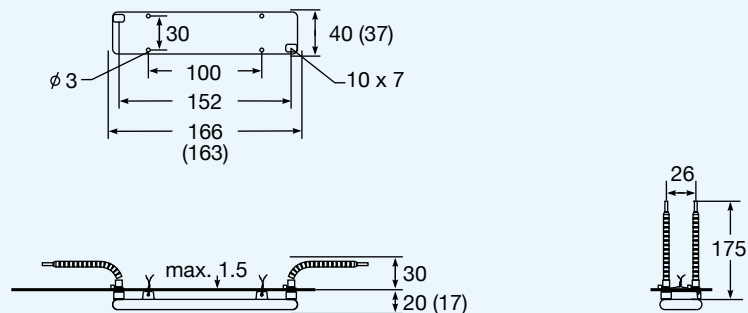
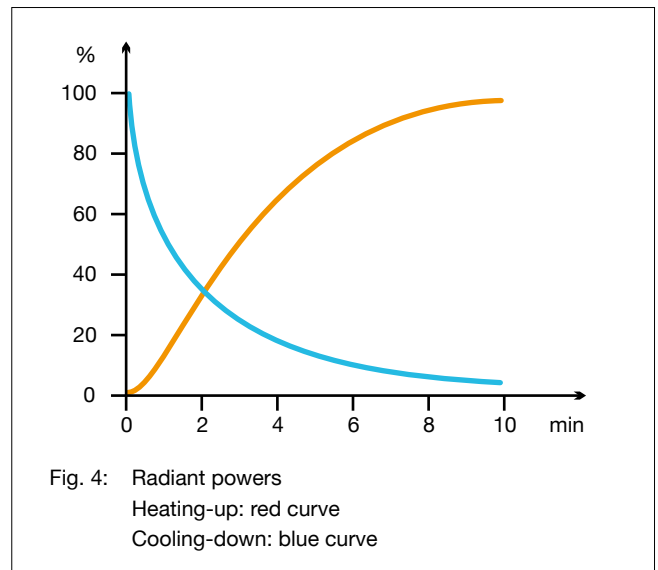
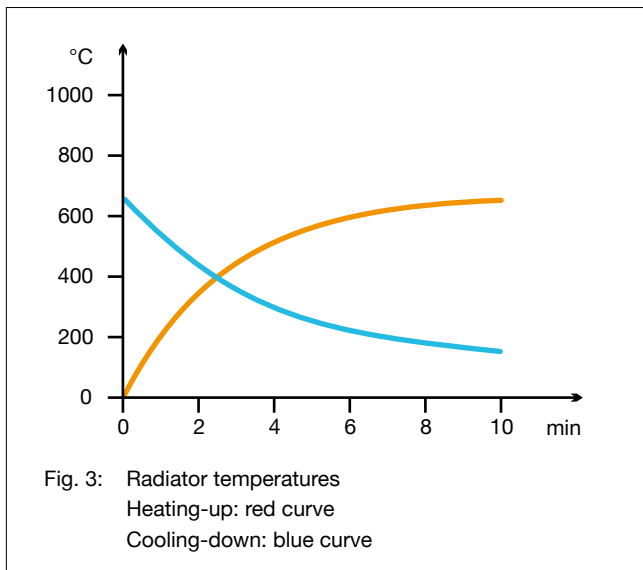



Figure 2: Mounting dimensions and radiator dimensions () in mm



Type, weight, wattage	FSL	220 g	600	W
	FSL/2	130 g	300	W
Surface rating			45.0	kW/m ²
Typical operating temperature			550	°C
Maximum permissible temperature			700	°C
Wavelength range			2 - 10	μm

Standard design Operating voltage 230 V Ceramic full-pour casting Leads 175 mm Two litz mountings	Thermocouple radiators Designation T-FSL, T-FSL/2 Integrated thermocouple Type K (NiCr-Ni) TC leads 110 mm 	Variants Special wattages Special voltages Extended leads Leads with ring terminals
--	--	--

The power can be controlled using thermocouple radiators together with TRD 1 temperature controllers, TSE thyristor switching units and other accessories.

The national safety regulations must be complied with for the respective application, for example, the IEC or EN standard 60519-1, Safety in electrical heating installations.

Our instructions for mounting, operation and safety must be observed.